

E1205

advanced multi-function indicator

Description

General

This specification describes the E1205 advanced multi-function weight indicator, capable of stand-alone operation, or of integration into a larger system via serial, FieldBus and Ethernet interfaces.

It is a microprocessor-based industrial weighing system with up to 100,000 displayed increments for analysing, displaying, storing and transmitting gross and net weight information.

Up to 12 load cells to be connected with the indicator (16 with second scale).

Analogue load cells or Avery Weigh-Tronix digital load cells may be used.

This indicator can display weight data from two scales simultaneously. Both scales are active and are independently weighing at all times.

The E1205 can be matched to almost any load cell system to achieve optimum accuracy, stability and repeatability.

The indicator can control its surrounding process using fully configurable I/O. Alternatively, control can be executed from a central system using an extensive range of available interfaces.

Configurable Features

The E1205 features a dual purpose alpha-numeric keyboard which allows any of the following functions to be configured during commissioning:



- Sensitivity to weight signal
- Scale capacity
- Number of divisions and increment size
- Weighing Unit
- Zero/back balance
- Decimal marker type - point or comma
- Position of decimal marker
- Calibration site gravity factor
- Customer site gravity factor
- Filtering using FIR or Harmonizer™ filtering systems
- Ten points for linearity correction to ensure maximum accuracy
- Tare availability and manner of operation
- Time and date (two or four digit year, battery backed)
- User-definable serial output strings
- Subtotal and grand total information
- Scale ID number
- Alarm index operation
- Recipe/filling I/O configuration

All these characteristics are stored in non-volatile memory so that once the ideal parameters for any given weighing system are established they can be retained with certainty for the future.

Once the scale is set up as required, a calibration report can be printed showing weighing details (useful for the installation engineer). This allows the state of the system to be monitored.

Up to 300 product look ups (PLUs) are available for instant recall of previously programmed product information.

Applications

Parts Counting

Sampling modes supported: fast; dribble; bulk

Static Weighing

Set limits, either absolute or relative to target. Set check-weigh bar step size.

In-Motion Weighing

The indicator can be used to control the in-motion process as required.

Peak Hold

Records maximum weight measured. Clear button resets memory

Weighbridge

A broad application, offering the following functions.

Three core operating modes -

- Re-entered first weight
- Stored and printed
- Stored first weight

Additional modes:

- Public weighing
- Axle weighing (up to 10 axles)
- Part loads
- Two platform in/out operation
- Simple stock control
- Net weight adjustment (dirt allowance)

Database supports:

- Vehicles
- Hauliers
- Suppliers / Customers
- Browsing
- Outstanding vehicle report

Three Level Pack Run Monitoring

Set all parameters to monitor and manage the packing of components into boxes, and overpacking into cartons and onto pallets. Produce all labels as required for tracking.

Conversion Factor

Enter the factor required to convert to custom unit

Recipe/Filling

Control of complete process using fully configurable trips. In-flight compensation and dosing variables may be set to optimise the process. Batching mode allows repetition of the process for a defined quantity.

Totalising Against Dedicated Product Look Ups (PLUs)

Link weighings to PLUs for complete stock control.

Product List Description and Totalising

Create customised print-outs itemising customer transactions, with grand totals.

Type Through Mode

Allowing any text to be input on the E1205 and printed out in full on an attached printer or suitable computer system.

Terminal Mode

Giving enhanced PC control and power.

Remote Display Mode

Connect to, or use as a remote display.

Specification

Electrical

Display

Type

Blue back-lit LED.
Graphics 64 x 240 pixels.
Displays up to eight digits.

Decimal Points

Configurable to any of seven positions

Units Displayed

g, kg, lb(dec), tons, tonnes, custom.

Annunciators

Balance (Gross Zero)
Motion
Pre-set Tare
Semi-Automatic Tare
Net
lb or kg
Print
Three-off Trip Indicators
Minus (below net zero)
Scale 1
Scale 2

Keypad

28 keys, addressing:
Alpha entry
Numeric entry
Five soft Function keys
Dedicated Function Keys
Zero, Tare, Select, Print, Units,
Totals, Scale, PLU, Standby,
Escape, Enter, Clear, Text

Remote IBM PS/2 keyboard input included (requires interface cable)

Load Cell Input

Analogue Input

Combined minimum load cell impedance must be greater than 22Ω.

Maximum Load Cells if 350Ω (One Scale)

12.

Total 350Ω Load Cells if 2nd Analogue Input Fitted

16.

Connection of Input

Direct wired (Buccaneer if supplied with scale).

Excitation

Direct current.

Voltage

10 V dc.

Current

Up to 460 mA

Remote Sense

Obtained from excitation, or Linked directly to reference input connectors at the indicator.

Input Impedance

1MΩ paralleled with 2.2nF.

Signal

6-20 mV maximum.

uV/ per Division

0.6

Resolution

Approved 10,000
Non- Approved 100,000

Calibration

Full digital multi-point (ten point) calibration.

Theoretical calibration possible if parameters known.

Provides over load report.

Increment Multiplier

1, 2, 5,10, 20, 50, 100, 200, 500.

AVR

Three stage.

Gravity Compensation

Set gravity for calibration and installation site.

Analogue to Digital Convertor

Display Update Rate

1, 2, 5, 10 per second.

A to D Rate

120 per second.

A to D Type

Delta Sigma.

Filter

FIR & Dynamic Filtering

Seven programmable Options

Filter Level	Associated Filter Attributes			
	Display Response Time (seconds)	Weight Sample Rate (Hz)	Noise Amplitude	Noise Frequency
0	0.20	8.13	Lowest	Highest
1	0.35	8.13		
2	0.53	8.13		
3	0.96	8.13		
4	1.45	8.13		
5	2.09	8.13		
6	2.85	8.13	Highest	Lowest

Dynamic Filter

Applied after the FIR filter. Set the filter window size in divisions (0 - 99). A high value will have a large damping effect on the weight display. This significantly slows the scale response to a legitimate change in weight.

Harmonizer™ Digital Filter

Three programmable parameters:

Samples to Average - sets number of A-D conversions which will be averaged to give a weight reading.

IIR Filter - sets how much damping the Harmonizer™ applies to the weight reading. Typically between 1 (low) - 8 (higher).

Threshold Level - sets the minimum weight change (in calibration units) which the Harmonizer™ will not attempt to filter out as noise.

Balance/Zero

Setting

Keyboard push button.

Operation

Ignore or recall limit exceeded.

Size of Balance Range

Normally 4%, up to 100%.

Zero Indication

Within 4% of maximum capacity.

Under Range Indication

Displays 'Under Range'.

Zero Tracking

Configurable

Motion Detection

Configurable.

Range/Span

Range of Adjustment

0 - 100,000 divisions.

Over Range Indication

Displays 'Over Range'.

Tares

Three types of tares are available. Each is 100% subtractive.

Note: Interlocks between the tare types are configurable at time of commissioning.

Type A - Push-Button (Semi Auto) Tare

Push-button operated, semi-automatic, with selectable negative weight display. Cumulative taring is possible.

Initialisation and Operation

When the item to tare on is applied, press the 'Tare' push-button.

Indication

'Net' annunciator is illuminated.

Type B – Keyboard (Pre-set) Tare

Keyboard-entered tare operated with negative weight display.

Initialisation & Operation

Enter pre-set tare value using the 0-9 keypad and press 'Tare' push button. Multiple pre-set tares are possible.

Indication

'Net' annunciator is illuminated together with pre-set tare annunciator (PT).

Type C - Stored Tare

Stored tare operated with negative weight display allowing 40 separate stored tares. Will be retained when power is off. Linked to any PLU.

Initialisation & Operation

Automatically activated when PLU activated.

Indication

'Net' icon is illuminated together with preset tare icon (PT).

Trips

The indicator has three internal trips as standard, and can support up to 16 external trips via external Trips Interface Units (see accessories).

All trips (both internal and external) are rated at 240 V 10 A. Internal inputs are rated at TTL levels.

Two modes have independent control of the trip outputs, Alarm and Recipe. Alarm mode operates continuously. Recipe mode is dependant on the Recipe / Filling application being configured and in operation.

Alarm Mode

Alarm mode has 10 independent configurable indexes, and cannot be turned off. Each index can be programmed to operate any or all outputs based on a given target:

- None - index inactive
- Target Weight
- Status of indicator, e.g. weight steady, checkweigh accept
- Input (single or specific pattern)
- Output (single or specific pattern)
- Time

Recipe /Filling Mode

Recipe/Filling mode has 20 configurable sequential steps, and is active only in Recipe/Filling mode. Each recipe (maximum 100) can be configured independently to the others. Each index can be programmed to operate any or all outputs based on a given target:

- None – index inactive
- Target Weight (includes tolerance, compensation and dosing parameters)
- Status of indicator, e.g. weight steady, checkweigh accept
- Input (single or specific pattern)
- Output (single or specific pattern)
- Time

Other variables that can be configured in Recipe / Filling mode are:

- Outputs at start of step
- Outputs at end of step
- Target action (e.g. print)
- PLU to accumulate totals data

All configuration information is retained when power is off.

Product Look Ups (PLUs) & Totals

Information Stored per PLU

Sub-totals and grand totals. Application specific info stored per PLU. Memory protection of PLUs.

Maximum capacity of each PLU

999,999,999.

User Definable Text Fields per PLU

3, each 21 characters.

When a PLU is recalled, the indicator is automatically configured into the application programme of the PLU. All information on the PLU can be displayed as well as printed.

Real Time Clock

The E1205 is fitted with a real time clock which allows the user to display and print the time and date. This clock is battery-backed and will remain functional in the absence of mains power.

Communications

Serial Interface

Two bi-directional asynchronous serial interfaces (RS232/485/422 and RS232/20mA current loop) as standard. Two additional via optional digital interface card.

Networking

Ethernet 10/100 TCP/IP interface as standard.

Fieldbus interfaces – optional – see Kits.

Electrical Power Input

Voltage

110 VAC - 230 VAC nominal,
50/60 Hz.

Tolerance

Voltage -15 to +10%.
Frequency $\pm 10\%$.

Power Consumption

30 VA maximum when used with
full configuration of load cells.

Cable Length

2 m.

Power Supply

Internally fitted, switched mode.

Isolation Protection

None. Mains earth lead must be
connected to safety earth.

Environment

Resistance to Dirt and Moisture

Protected to IP54, in moulded
plastic enclosure.

Electrical Disturbance

Immune to electrical disturbance,
including RFI as detailed in
EN 45501:1992

Operating Temperature

-10° C to + 40° C.

Service Temperature

-10° C to + 55° C.

Storage Temperature

-40° C to +70° C.

Finish

Enclosed in moulded ABS plastic
case.

Mounting Options

The indicator will desk, wall or
pole mount.

Pole mounting requires optional
adapter.

Performance

Internal Resolution

16,777,216.

Repeatability

$\pm 0.01\%$ of full scale.

Span Drift Time

± 50 ppm/year max.

Span Drift Temperature

± 4 ppm/° C typical.

Zero Drift Time

± 10 ppm $\pm 0.1\%$ DL/year
maximum.

Zero Drift Temperature

± 2 ppm ± 40 ppm DL/ °C
maximum.

Warm Up Time

Immediate self test complete.

Self Diagnostics

Graphics Display

Keys

PS/2 Keyboard

A2D (x 2)

Serial Test (4)

Network interface

Ethernet port

BCD Out

Analogue Out

Pulse In

Memory

Tally Roll

Internal I/O

External I/O

Approvals

All data relating to the
performance of the machine
meets and exceeds requirements
of EN 45501:1992 European
Approval ('E' Approval) Accuracy
Class III Machines and
OIML 76-1. The type approval
certificate numbers being:

EU	- UK2694
South Africa	-
New Zealand	-
Australia	-
OIML	- R76/1992-GB1- 04.03 Revision 1

Factory Options

Choice of mains power connector:
UK, Euro, Australian, South
African, American.

Kits

The following kits are available to enable local configuration when required.

1. Analogue Card

Provides second analogue scale input and two analogue outputs 4-20 mA.

E11050F00000000

2. Digital Card

Provides two additional bi-directional asynchronous serial interfaces (RS232/485/422 and RS232). Also includes BCD output (range 1 - 100,000) and pulse input.

E11050G00000000

3. Electronic Tally Roll Card

Securely stores and prints up to 72,000 transactions, with details of scale ID, gross/tare/net weights, time, date and consecutive number.

Also acts as carrier for FieldBus card.

E11050H00000000

4. ProfiBus Interface Kit

Enables interfacing to ProfiBus network. Includes Electronic Tally Roll card (*E11050H00000000*) as standard to provide interface.

E11050J00000000

5. ControlNet Interface Kit

Enables interfacing to ControlNet network. Includes Electronic Tally Roll card (*E11050H00000000*) as standard to provide interface.

E11050K00000000

6. DeviceNet Interface Kit

Enables interfacing to DeviceNet network. Includes Electronic Tally Roll card (*E11050H00000000*) as standard to provide interface.

E11050L00000000

7. Ethernet IP Interface Kit

Enables interfacing to Ethernet Industrial Protocol (IP) network. Includes Electronic Tally Roll card (*E11050H00000000*) as standard to provide interface.

E11050M00000000

8. ModBus TCP Interface Kit

Enables interfacing to ModBus TCP or Ethernet (over Modbus TCP) network.

Includes Electronic Tally Roll card (*E11050H00000000*) as standard to provide interface.

E11050N00000000

9. Load Cell Connector With Internal Loom

When fitted, provides ability to disconnect load cell inputs from indicator without opening the unit.

70735-247

Accessories

1. External Lightning Protection Box

When fitted between the load cell/ junction box, and load cell input, provides additional protection from lightning.

E11050B00000000

2. Trips Interface Unit (TIU8)

Provides eight external I/O in place of three internal I/O included as standard.

Inputs rated at 12 V, outputs rated at 240 V 10 A.

Two TIU8s may be connected to the E1210 to provide a total of 16 I/O.

E11100E00000000

3. 300 mm Pole

Stainless steel mounting pole with top mounting plate for indicator.

E11100U00000000

4. 1000 mm Pole

Stainless steel mounting pole with top mounting plate for indicator

E11100V00000000

5. Interface Leads for Platform to Indicator

See price list.

6. Interface Leads for Indicator to Printer

See price list.

7. Y808

Large push button unit (up to four buttons).

Weight

2.0 kg

Shipping Specification

Net

2.0 kg

Gross

4.6 kg

Measurement

345 mm x 270 mm x 335 mm

Harmonised Commodity Code

842390 00 0.

Dimensions

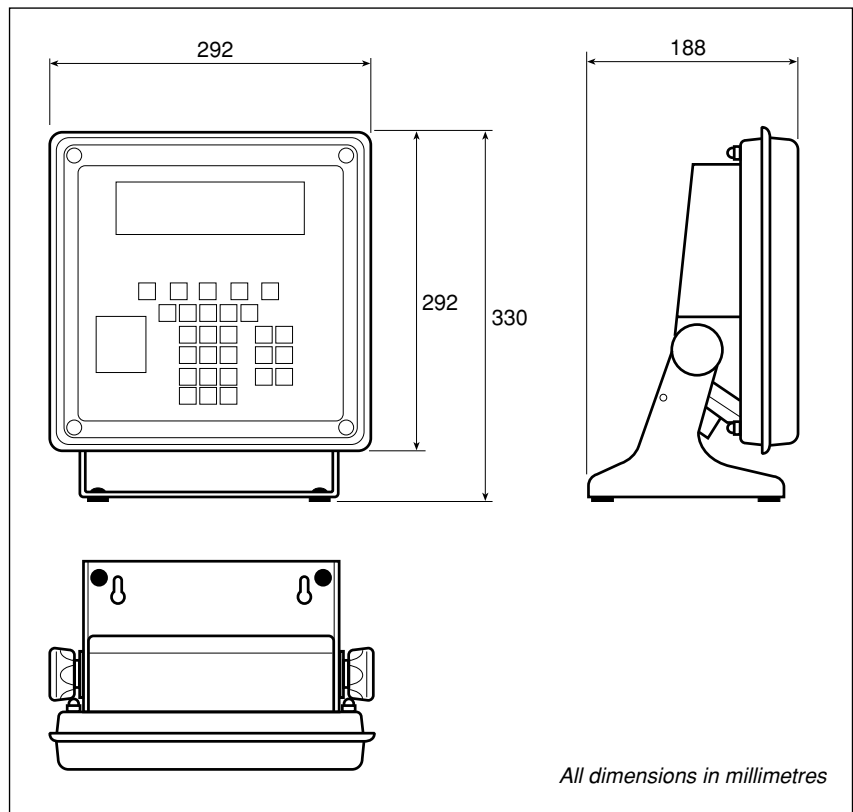

© Avery Berkel Limited 2004. All rights reserved. This publication is issued to provide outline information only which, unless agreed by Avery Berkel Limited in writing, may not be regarded as a representation relating to the products or services concerned. Avery Berkel Limited reserves the right to alter without notice the specification, design, price or conditions of supply of any product or service.

Your local distributor:

Avery Weigh-Tronix

E mail: info@awtxglobal.com
Internet: <http://www.averyweigh-tronix.com>

Foundry Lane, Smethwick,
West Midlands, England B66 2LP.
Tel: +44 (0)870 90 34343 Fax: +44 (0)121-224 8183