

SBX1KL3000-4500

SBX-1KL SERIES SHEAR BEAM LOAD CELLS, from 3000kg to 4500kg



Stainless steel approved shear beam load cells, suitable for creating CE-M approved scales with 4 load cells, or for weighing tanks and hoppers, with the aid of its accessories.

CAPACITIES (kg): 3000, 4500.

OIML R60. C3 precision class.

Stainless steel. IP68 protection.

Working in cooperation with:

HUNTEK SYSTEM CO., LTD

3F.NO 138, SEC 1, GUANGFU ROAD - - SANCHONG CITY-TAIPEI COUNTY - TAIWAN
Tel. 00886-2-85111234 Fax. 00886-2-85111243
fred.chan@huntek.com.tw

The best solution
for advanced industrial
applications

MAIN FEATURES

- C3 PRECISION CLASS
- STAINLESS STEEL CONSTRUCTION WITH LASER WELDING
- IP68 PROTECTION
- MAX. CAPACITIES FROM 3000 TO 4500 kg
- SHIELDED CONNECTION CABLE
- TEST CERTIFICATE AVAILABLE UPON REQUEST

TECHNICAL FEATURES

- Minimum load cell verification interval $V_{min} = E_{Max} / 10.000$
- Maximum number of verification intervals: $n_{LC} = 3000$
- Combined error 0,017% of Full Scale Output (F.S.)
- Full Scale Output 2mV/V +/- 0.5%
- Temperature effect on zero 0,002% / °C
- Temperature effect on full scale output 0,002% / °C
- Compensated Temperature Range -10°C/+50°C
- Operating Temperature Range -20°C/+60°C
- Creep error after 30 minutes 0,02% F.S.
- Maximum tolerated excitation voltage 15 VDC
- Input Resistance 1100 ± 20 Ohm
- Output Resistance 1000 ± 20 Ohm
- Insulation Resistance: >5000 MOhm
- Safe Overload 150% F.S.
- Ultimate Overload 300% F.S.
- 6-wire shielded cable, 5m long, 5 mm diameter

ATEX VERSION

- The CCATEX certificate makes the load cell suitable for use in hazardous areas with protection methods according to:
ATEX II 1G Ex ia IIC T6 (Ta -20÷+40°C) TX (Ta -20÷+65°C) Ga
ATEX II 1D Ex ta IIIC TX°C (Ta -20÷+40°C) TX°C (Ta -20÷+65°C) Da IP65.
The certificate includes the manual and the ATEX CE conformity declaration (available in EN, DE, FR, and IT).
- IMPORTANT: the certificate refers to the single load cell. For systems with more load cells, it is necessary to order one certificate for each load cell.

DIMENSIONS - DECODING STANDARD CABLE

- NOTE: dimensions in mm

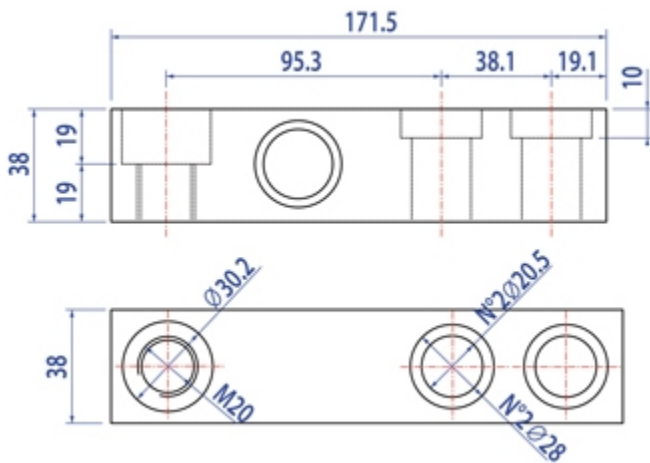

- Decoding of the standard cable colours

Colour	Function
--	SHIELD
YELLOW	OUTPUT +
GREY	SENSE +
BROWN	INPUT +
WHITE	OUTPUT -
GREEN	INPUT -
PINK	SENSE -

VERSIONS

Versioni disponibili

Codice	Max (kg)
SBX3000-1KL 	3000
SBX4500-1KL 	4500



www.diniargeo.com



“YOUR WORLDWIDE PARTNER FOR WEIGHING,”

DINI ARGEO
FRANCE sarl
Nogent-sur-Marne

DINI ARGEO
GMBH
Sinsheim - Germany

DINI ARGEO
UK Ltd
Taunton - United Kingdom

DINI ARGEO WEIGHING
INSTRUMENTS Ltd
Shanghai - China

DINI ARGEO
WEIGHBRIDGES
Calto (RO) – Italy



HEAD OFFICE
Via Della Fisica, 20
41042 Spezzano di Fiorano Modena - Italy



HUNTEK SYSTEM CO., LTD

3F.NO 138, SEC 1, GUANGFU ROAD - - SANCHONG CITY-TAIPEI COUNTY - TAIWAN

Tel. 00886-2-85111234 Fax. 00886-2-85111243

fred.chan@huntek.com.tw

SALES AND TECHNICAL ASSISTANCE SERVICE